

MODEL 700

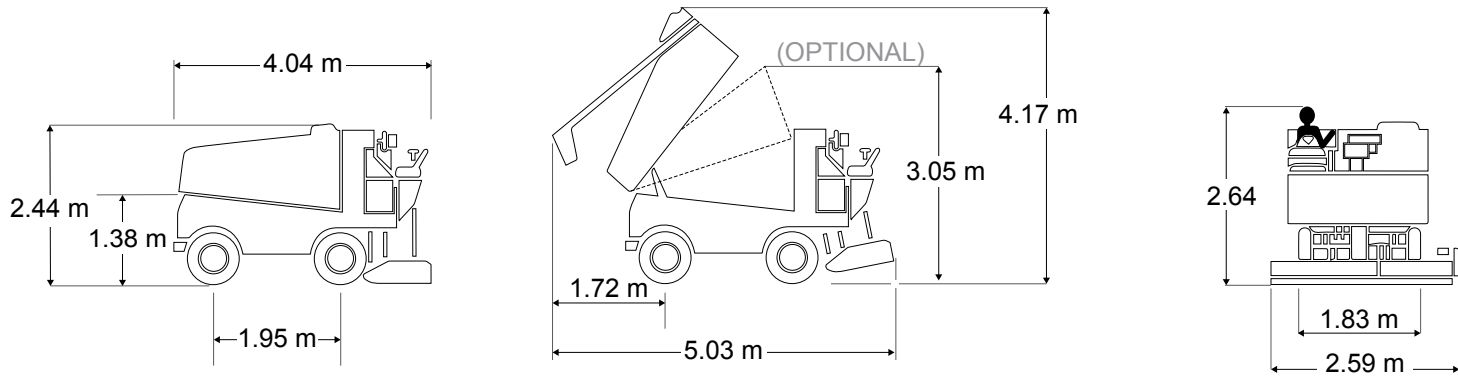

CAPACITIES		
Snow Tank		
Actual Volume	3.54 m ³	125 cu. ft.
Compacted	4.53 m ³	160 cu. ft.
Excess Water	662 L	175 gal.
Water		
Ice Making	1514 L	400 gal.
Wash Water	416 L	110 gal.
Total	1930 L	510 gal.
Hydraulic Oil	125 L	33 gal.
POWERTRAIN		
Four-Wheel Drive		
Engine	GM® 4.3 L Six Cylinder Engine 75 kW / 100 HP at 2800 RPM	
Transmission	Continuously variable hydrostatic pump and motor are axial-piston type.	
Hydraulics	Double pump powers the vertical and horizontal augers. Hydraulic down pressure for optimal resurfacing results.	
Axles	Rugged Dana Spicer® Model 70 Axles	
Brakes	Full Hydrodynamic Braking	

DIMENSIONS						
Overall	L	W	H	L	W	H
Snow Tank Down	4.04 m	2.59 m	2.44 m	159 in.	102 in.	96 in.
Snow Tank Up	5.03 m	2.59 m	4.17 m	198 in.	102 in.	164 in.
Shaving Blade	L	W	H	L	W	H
	243.8 cm	12.7 cm	1.27 cm	96 in.	5 in.	0.5 in.
Clearance						
Minimum Operator Height Clearance			264.2 cm		104 in.	
Snow Pit Clearance			1.38 m		54.5 in.	
Conveyor System						
Horizontal Auger Diameter			25.4 cm		10 in.	
Vertical Auger Diameter			25.4 cm		10 in.	
Manueverability						
Wheelbase			1.96 m		77 in.	
Wheel Track			1.83 m		72 in.	
Turning Radius at Conditioner			6.1 m		20 ft.	
Weight						
Empty			4273 kg		9420 lb	
with Water			6214 kg		13700 lb	