

MODEL 526

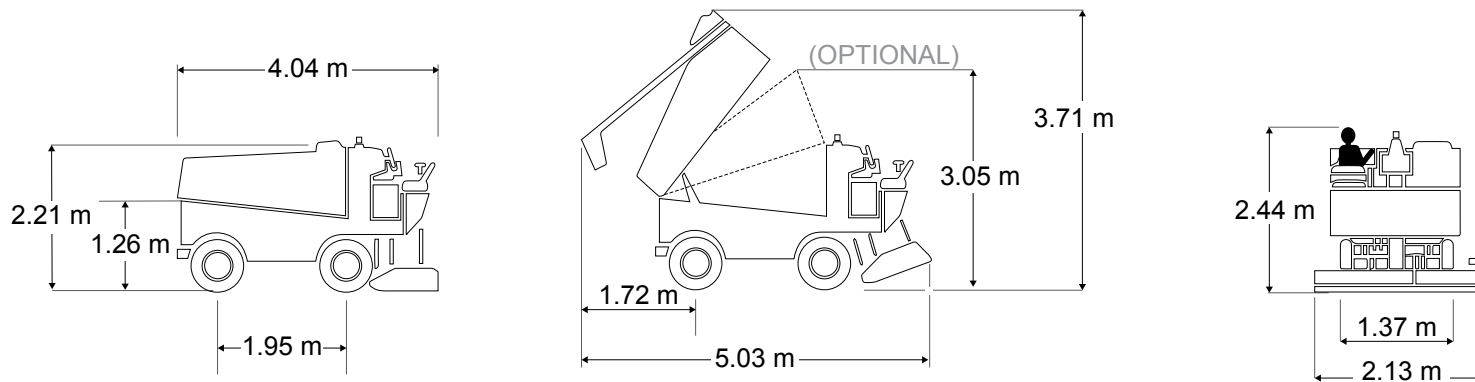

CAPACITIES

Snow Tank

Actual Volume	2.83 m ³	100 cu. ft.
Compacted	3.54 m ³	125 cu. ft.
Excess Water	416 L	110 gal.

Water

Ice Making	727 L	192 gal.
Wash Water	273 L	72 gal.
Total	1000 L	264 gal.

Hydraulic Oil	95 L	25 gal.
----------------------	------	---------

POWERTRAIN

Four-Wheel Drive

Engine	Mitsubishi® 2.4 L / 59 HP at 2500 RPM Four Cylinder Liquid Cooled
Transmission	Continuously variable hydrostatic pump and motor are axial-piston type.
Hydraulics	Double pump powers the vertical and horizontal augers. Hydraulic down pressure for optimal resurfacing results.

Axles

Front	1950 kg	4300 lb
Rear	2903 kg	6400 lb

Brakes	Full Hydrodynamic Braking
---------------	---------------------------

DIMENSIONS

Overall

	L	W	H	L	W	H
Snow Tank Down	4.04 m	2.13 m	2.21 m	159 in.	84 in.	87 in.
Snow Tank Up	5.03 m	2.13 m	3.71 m	198 in.	84 in.	146 in.

Shaving Blade

	L	W	H	L	W	H
	195.6 cm	12.7 cm	1.27 cm	77 in.	5 in.	0.5 in.

Clearance

Minimum Operator Height Clearance	243.8 cm	96 in.
Snow Pit Clearance	125.7 cm	49.5 in.

Conveyor System

Horizontal Auger Diameter	25.4 cm	10 in.
Vertical Auger Diameter	25.4 cm	10 in.

Manueverability

Wheelbase	1.96 m	77 in.
Wheel Track	1.37 m	54 in.
Turning Radius at Conditioner	4.86 m	16 ft.

Weight

Empty	3143 kg	6930 lb
with Water	4240 kg	9350 lb